



ROMLAIR

9668 Heinrich Hertz Dr # D, San Diego, CA 92154
PH. 619-946-1224

**MODEL CLS
Centrifugal Filtered Supply Fans**

INSTALLATION AND MAINTENANCE INSTRUCTIONS

This publication contains the installation, operation and maintenance instructions for standard units of the CLS- Centrifugal Filtered Supply Fans. Carefully read this publication prior to any installation or maintenance procedure.

The Romlair catalog, CLS, provides additional information describing the equipment, fan performance, and available accessories.

For additional safety information, refer to AMCA publication 410-96, Safety Practices for Users and Installers of Industrial and Commercial Fans.

Receiving and Inspection

Inspect the fan and accessories for any damage and shortage immediately upon receipt of the fan.

- Rotate the blower wheel by hand to ensure it turns freely. If necessary, shift wheel position and re tighten.
- Inspect dampers (dampers are optional), for good operation.

Handling

Lifting Lugs are installed on the base to facilitate lifting. Never lift by the louver tiers.

WARNING

This unit has rotating parts. Safety precautions should be exercised at all times during installation, operation, and maintenance.
ALWAYS DISCONNECT POWER PRIOR TO WORKING ON FAN.

Storage

Any time the fan is stored for a length of time prior to installation, fill the bearings with grease or moisture-inhibiting oil. The blower wheel should be rotated every three to five days to keep a coating of grease on all internal bearing parts.

The fan should be stored in its original crate and protected from dust, debris and the weather.

Personal Safety

Disconnect switches are recommended. Place the disconnect switch near the fan in order that the power can be cut off quickly in case of an emergency, and in order that maintenance personnel are provided complete control of the power source.

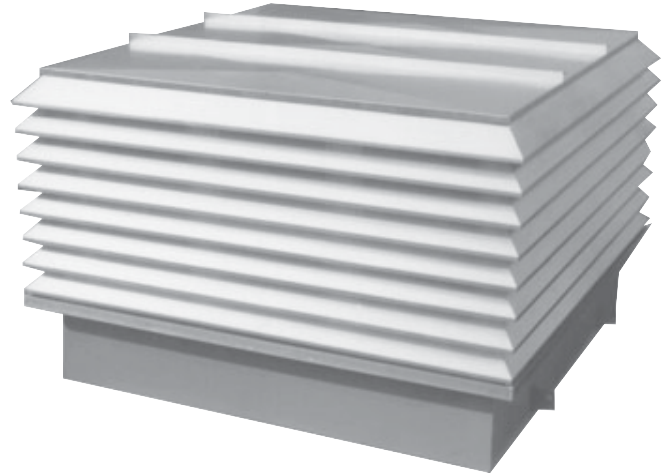

Installation

Motor Installation

Most units come with the motors, belts, and drives installed. No installation of motor and drives are required.

Duct Installation

Good fan performance requires proper installation of inlet and discharge ducts. The fan should conform to the following guidelines.

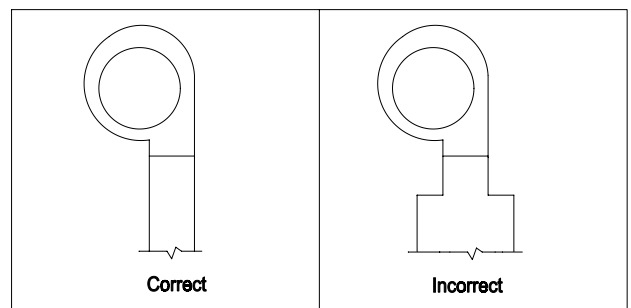

Free Discharge

Free Discharge

A free discharge into the plenum should be avoided. Free discharge into the plenum does not allow for a static gain, resulting in loss efficiency.

Discharge Duct Turns

It is good practice to allow 3 duct diameters between duct turns or elbows and the fan outlet. Refer to the following drawing.

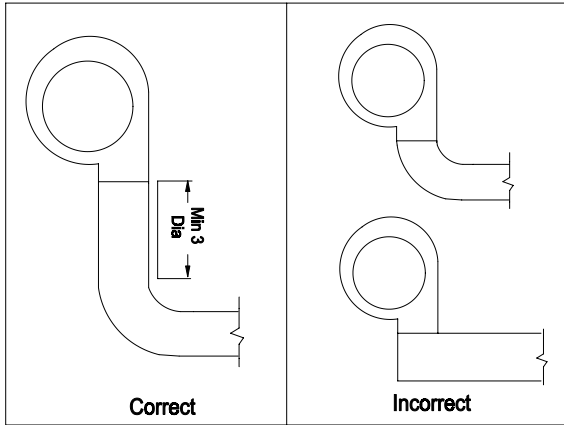

Wheel-to-Inlet Clearance

Wheel-to-inlet clearance is very important for optimal fan performance. This clearance should be checked before initial start-up. Handling during shipping can cause a shift in these components. Reference the below table for correct wheel overlap.

The overlap can be adjusted by loosening the wheel hub and moving the wheel until you obtain the correct overlap.

A uniform radial gap between the edge of the wheel shroud and the edge of the inlet cone is obtained by loosening the inlet cone bolts and repositioning the inlet cone.

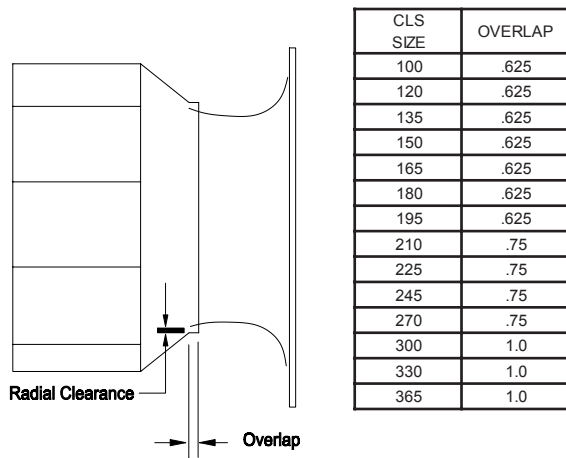

Wiring Diagrams

Wiring diagrams are located on the motor nameplate. If a hard copy is required please contact the factory.

Wiring Installation

All wiring should be in accordance with local ordinances and the National Electrical Code, NFPA70. Verify that the voltage, frequency, and current carrying capacity of wires is in accordance with the motor nameplate.

Lock off all power sources before unit is wired to power source.

It is important to allow enough slack in the wiring to allow for motor movement when adjusting belt tension.

Personal Safety

Disconnect switches are recommended. The disconnect switch should be near the blower in order that the power can be quickly cut off in case of an emergency, and in order that maintenance personnel are able to control the power source

Follow the wiring diagram provided with the motor and the disconnect switch. Correctly label the circuit on the main power box and always identify a closed switch to promote safety.

Wheel Rotation

Test the fan to observe the rotation of the blower wheel and to ensure the rotation is the same as indicated by the direction arrow.

On 3 phase motors, If the wheel is rotating in the wrong direction, reverse rotation by switching two of the supply leads. For this reason, the rotation of the fan cannot be restricted to one direction at the factory. 115v and 230v single phase motor are set correctly at the factory. Changing the rotation of these motors should only be attempted by a qualified electrician.

If you allow the fan to operate in the wrong direction, the motor will overheat and cause serious damage. On 3-phase motors, if the fan is operating in the wrong direction, check the control switch. You may be able to interchange two leads at this location so that the fan is operating in the correct rotation.

Proper Wheel Rotation

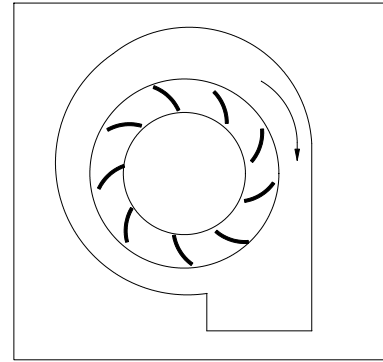

Airfoil

Rotation is always determined by viewing the wheel from the drive side and should correspond to the rotation decal affixed to the unit.

Belt and Pulley Installation

Proper belt tension is important. If the belt tension is too tight or too loose, lost efficiency and possible damage is possible.

It is important **not** to change the pulley pitch diameter to change tension. This will change the fan speed and performance.

Adjusting Belt Tension

1. Loosen the adjustment bolts on the adjustable motor plate. Position the motor so that the belts easily slip into the pulley grooves. Avoid prying, rolling or forcing the belts over the rim of the pulley.

2. Adjust the motor until belts appear snug. Run the unit for a few minutes and allow the belts to "Set" properly. As shown below, a deflection of approximately 1/4" per foot of center distance would be obtained by firmly pressing the belt.

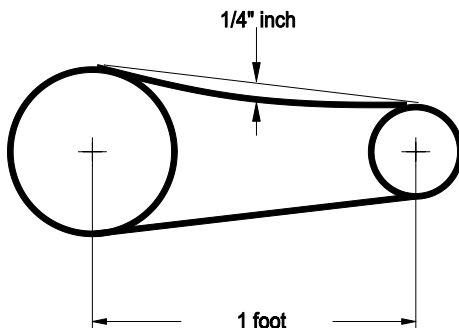

3. Tighten securely the motor base nuts.

4. Verify that the pulleys are correctly aligned.

Pulley Alignment

The drawing below illustrates correct pulley alignment. Align fan and motor sheaves with a straight-edge or string and tighten.

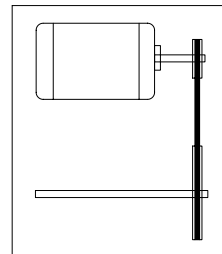

Proper Sheave Alignment

Final Installation Steps

- All fasteners and setscrews should be inspected and tightened. Refer to the recommended torque tables below.
- Verify all voltage with voltmeter.

Recommended Torque For Setscrews			
Size	Key Hex Across Flats	Min	Max
No. 10	3/32"	28	33
1/4"	1/8"	66	80
5/16"	5/32"	126	156
3/8"	3/16"	228	275
7/16"	7/32"	348	384
1/2"	1/4"	504	600
5/8"	5/16"	1104	1200
3/4"	3/8"	1440	1800

Recommended Torque For Hold Down Bolts	
Size	Wrench Torque
3/8"-16	240
1/2"-13	600
5/8"-11	1200
3/4"-10	2100
7/8"-9	2040
1"-8	3000
1-1/8"-7	4200
1-1/4"-7	6000

Pre- Start Up

1. Disconnect and lock-out all power switches to fan. See warning below.
2. Check all fasteners, set screws and locking collars on the fan, bearings, drive, motor base and accessories for tightness.
3. Inspect the V-belt drive for proper alignment and tension.
4. Check all electrical connections.
5. Check housing and ductwork for obstructions and foreign material that may damage the fan wheel.
6. Check wheel-to-inlet clearances for maximum performance
7. Restore power to fan.

WARNING

This unit has rotating parts. Safety precautions should be exercised at all times during installation, operation, and maintenance.
ALWAYS DISCONNECT POWER PRIOR TO WORKING ON FAN.

Start Up

Start the fan and inspect the following:

- Rotation.
- Excessive vibration.
- Unusual noise.
- Bearing noise.
- Improper belt alignment or tension.
- Incorrect motor amperage or voltage.

Immediately shut the fan down if a problem is discovered. Lock out all electrical power and check for cause of the trouble.

Filters and Filter Care

Filters must be cleaned regularly to prevent undue resistance and a loss of filtering efficiency. Visual inspection at regular intervals is probably the best method for determining when it is time to clean and change filters. These filters can be easily removed by unbolting and removing the louver section hood, and sliding the filters out.

Remove excess dust and lint by rapping dirty side down. Clean filters by flushing with a stream of water from both the exhaust and intake side. If filters are extremely dirty or linted, fill container with warm water and a mild soap solution, and "swish" filters in water. Rinse clean and allow to dry.

Replacement Filters.

Aluminum replacement filters can be supplied by factory if required. The filter sizes for each size are listed in the following table.

UNIT SIZE	NOMINAL FILTER SIZE (2"THICK)
12	(4) 16X20 (4) 20X20
13	(8) 20X20
15	(8) 20X25
16	(8) 20X25
18	(8) 20X25 (4) 16X25
20	(8) 20X25 (4) 16X25
22	(8) 20X25 (4) 16X25
24	(12) 16X20 (12) 20X20
27	(12) 16X25 (12) 20X25
30	(24) 20X25
33	(16) 20X20 (16) 20X25
36	(16) 20X20 (16) 20X25 (4) 16X25

Routine Maintenance

Once the unit has been put into operation, a routine maintenance schedule should be set up to do the following.

1. Periodic lubrication of bearings and motor.
2. Wheel, housing, bolts and set screws on the entire fan should be checked for tightness.
3. Any dirt accumulation on the wheel or in the housing should be removed to prevent unbalance and possible damage.
4. Springs and rubber isolators should be inspected for deterioration and replaced if required.
5. Inspect blower wheel and housing looking for

Lubricants

The factory uses a high quality lithium base grease conforming to NLGI Grade 2 consistency, such as those listed below.

MOBILITH SHC 220
MOBILITH AW2
TEXACO MULTIFAK AFB2
TEXACO PREMIUM RB
SHELL ALVANIA #2
EXXON UNIREX N2

Never mix grease made with different bases. This will cause a breakdown of the grease and possible failure of the bearing.

Motor Bearings

Motor maintenance is generally limited to cleaning and lubrication. Cleaning should be limited to exterior surfaces only. Removing dust and grease buildup on the motor housing assists proper motor cooling. Never wash-down motor with high pressure spray. Greasing of motors is only intended when fittings are provided. Many motors are permanently lubricated for life and require no further lubrication. Under normal conditions they will not require further maintenance for a period of ten years. Motors supplied with grease fitting should be greased in accordance with manufacturer's recommendations.

Bearing Lubrication

The most common cause of premature bearing failure is improper lubrication. Greasable fan bearings are lubricated through a grease fitting on the bearing and should be lubricated by the guidelines recommended by the following relubrication schedule.

RELUBRICATION SCHEDULE (MONTHS)* Ball Bearing Pillow Blocks									
SPEED (RPM)	500	1000	1500	2000	2500	3000	3500	4000	4500
SHAFT DIAMETER									
1/2" thru 1-11/16"									
1-15/16" thru 2-3/16"									
2-11/16" thru 2-15/16"									
3-7/16" thru 3-15/16"									

* Suggested initial greasing interval-relubricate while running. If safety permits, until some purging occurs at seals. Adjust lubrication frequency depending on condition or purged grease. Hours of operation, temperature, and surrounding conditions will affect the relubrication frequency required.

Puddle corrosion is often encountered in failed bearing, particularly if the fan has been shut down for a period of time. Moisture caused by condensation will accumulate in the bearings and create corrosion in the race ways. If fans are to be shut down or stored for more than 30 days it is important that the bearings are filled with grease and the fan rotated by hand from time to time so that the grease can be spread on bearing components. All bearings are filled with grease before leaving the factory. When the fans are started, the bearings may discharge excess grease through the seals after a short period of operation, but do not replace this initial discharge because leakage will cease when the excess grease has worked out. Sometimes the bearing has a tendency to run hotter during this period and one should not get alarmed unless it lasts over 48 hours or gets very hot. When relubricating use sufficient amount of grease to purge the seals. For best results, lubricate the bearing while the fan is in operation. Pump grease slowly until a slight bead forms around the bearing seals. Excessive grease can burst seals thus reducing the bearing life.

When a bearing failure occurs, it is important that the failed bearings be preserved as well as possible and returned to the factory for examination so that the cause of failure can be established and corrective measures taken. The only way to know the cause of failure is to supply as much information as possible about the operating condition. Before installing a new bearing on the existing shaft, a check must be made to ensure that the shaft has not worn down below commercial tolerances, which would cause a rapid failure of the new bearings.

Motor Services

Should the motor prove defective within the one year warranty period, contact Romlair or your nearest authorized electric motor service center. The motor will be repaired for replaced at the manufacturer's option.

Changing Shaft Speed

All belt driven fans up to and including 7-1/2 Hp are equipped with variable pitch drives. To change the fan speed, perform the following.

1. Loosen setscrew on driver pulley and remove key, if applicable.
2. Turn the pulley rim to open or close the groove facing. If the pulley has multiple grooves, all need to be adjusted to the same width.
3. After adjustment, inspect for proper belt tension.

Speed Reduction

Open the pulley in order that the belt rides deeper in the groove. This results in a smaller pitch diameter.

Speed Increase

Close the pulley in order that the belt rides higher in the groove. This results in a larger pitch diameter. Verify that the new RPM of the fan is within the horsepower limits of the motor.

Pulley and Belt Replacement

1. Remove pulleys.
2. Clean the motor and fan shafts, and bores of pulleys. Coat the bores with a heavy grade oil.
3. Remove any burrs from shafting by sanding.
4. Install both pulleys on their respective shaft. The pulleys can be damaged if excessive force is used on placing the sheaves on their shafts.
5. Tighten the pulleys in place.
6. Install the belts. Refer to the Belt and Pulley Installation section in the manual.

CAUTION:

When operating conditions of the fan are to be changed (speed, pressure, temperature, etc.) consult Romlair to determine if the unit can operate safely at the new conditions.

Troubleshooting

Problem	Potential Cause and Corrective Action
Excessive Noise	Wheel-Inlet Contact - Blower wheel and/or inlet cone may require adjustment. After adjustment tighten wheel hub or locking bearing collars on fan shaft.
	V-Belt Drive - Inspect and adjust belt tension and align sheaves per instructions in this manual.
	Bearings Need Lubrication or Replacement - Replace or lubricate bearings.
	Damaged or Unbalanced Wheel - Clean wheel and check balance. Have wheel rebalanced in place.
Low Capacity	Fan - Verify correct wheel rotation - Increase motor speed. Be careful not to overload the motor.
	Poor Fan Inlet Conditions - Make required changes in inlet and discharge ducts.
Pressure Difference	Duct System Has More or Less Resistance Loss Than Anticipated - Change obstructions in duct. Resize duct, clean filters, or change fan speed.*
Overloaded Motor	Fan - Check rotation of blower wheel and correct if required - Reduce fan speed.
	Duct System -Resize or adjust ductwork.
Non-Operation of Fan	Electrical Supply - Check circuit breakers, switches turned off or disconnected, or correct power supply.
	Fan Drives - Check for any broken belts or loose pulleys.
	Fan Motor - Verify motor horsepower is correct and not setting off overload protection.
Overheated Bearings	Improper Bearing Lubrication - Refer to lubrication instructions in this manual.
	Excessive Belt Tension - Relieve excessive belt tension.
Excessive Vibration	Belts - Adjust belt tension or replace belts.
	Shaft Alignment - Replace shaft.
	Damage or UnBalanced Wheel - Repair and rebalance.
	Incorrect Direction of Rotation - Verify rotation and reverse rotation per instructions in manual.
	Bearings Need Lubrication of Replacement - Inspect bearing and replace if required.
	Pulleys - Adjustable pitch pulleys with motors over 15 hp motors are sometimes prone to unbalance.

* Always check motor amps and compare to nameplate rating. Excessive fan speed may overload the motor and result in motor failure. Do not exceed the maximum cataloged rpm of the fan.

NOTE: Always provide the Romlair Model number and serial number when requesting parts or service information.

Typical Installation - Model CLS

The following detail shows recommended locations for accessories, options and items supplied by others.

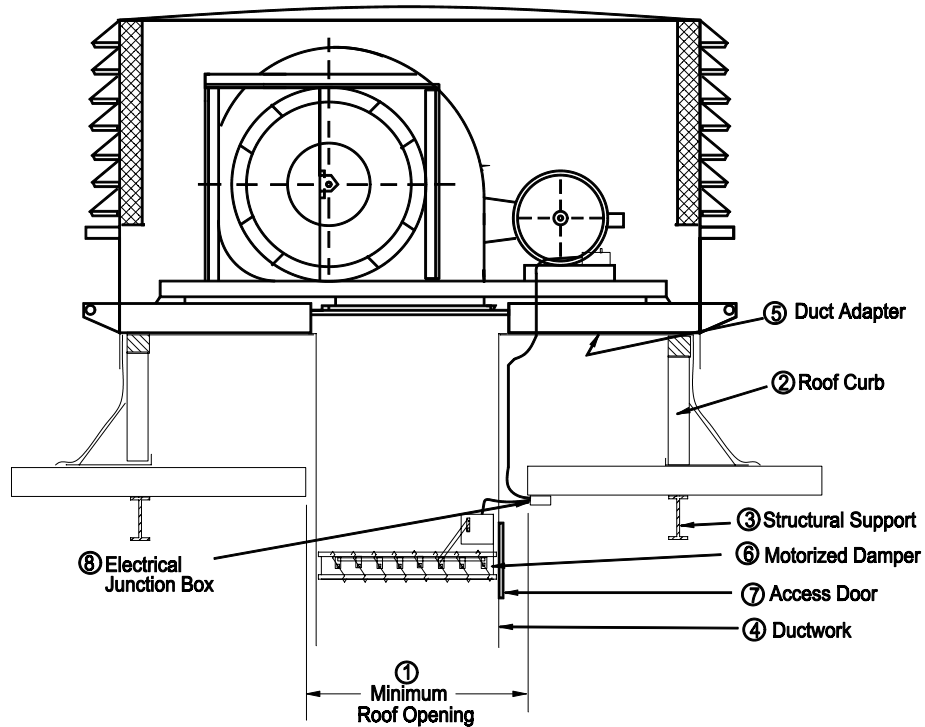

1. Refer to the minimum opening required for the fan sizes. The roof opening may be made larger.
2. Romlair Model CF roof curb (Extra Heavy Duty) are designed to accommodate the weight of the Model CLS.
3. Additional supports may be required beneath the load-carrying sides of the fan and roof curb as shown. Refer to unit weights.
4. A minimum length of duct is recommended from the roof curb to the roof opening. This duct is recommended for use in non-ducted as well as ducted installations. Reduced turbulence between the fan discharge and the damper will result.
5. The standard duct adapter locates the top of duct allowing the installer to complete the ductwork before the fan is set in place. Additional support is required for ductwork.
6. When installing motorized dampers, locate them below the roof line for easier access.
7. When motorized dampers are used, installer should supply an access door located as shown in the duct to allow access for service.
8. Locate the electrical junction box to facilitate wiring of both fan motor and actuator.

DIMENSION DATA - WEIGHTS

UNIT SIZE	A*	E	F	Duct/Damper		Min. Roof Open		WT
				X	Y	ROW	ROL	
12	46	21	25	18	14	22	18	425
13	52	22	30	20	16	24	20	475
15	58	24	34	22	16	26	20	650
16	58	26	32	24	18	28	22	715
18	64	29	35	26	20	30	24	905
20	70	31	39	30	22	34	26	1000
22	70	34	36	32	24	36	28	1100
24	76	36	40	36	26	40	30	1650
27	82	40	42	40	30	44	34	1900
30	88	44	44	44	32	48	36	2300
33	88 X 96	48	48	48	36	52	40	2600
36	88 X 106	51	55	52	40	56	44	3200

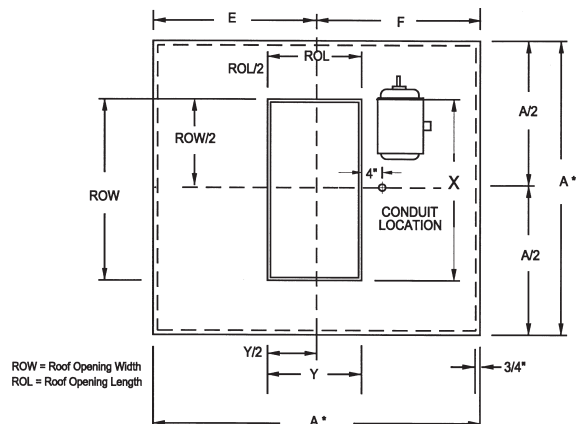

Limited Warranty

The Romla Ventilator Company warrants this equipment to be free from defects in material and workmanship under normal use and service for a period of one year from date of delivery. During the warranty period if any parts prove to be defective, they will be repaired or replaced free of charge at factory option: If upon receipt of written authorization they are delivered prepaid to the factory. This guarantee does not cover any damage caused by neglect of lubrication, accident or overload, improper installation, nor does it cover the cost of repairs made or attempted outside the factory, without authorization from Romla Ventilator Company. Electric motors are guaranteed only to the extent of the motor manufacturer's warranty. Romla Ventilator is not responsible for the cost of removal of the defective product or part, or the installation of the repaired or replaced products or part. Correction of any verified defects by repair or replacement shall constitute fulfillment of this warranty.

ROMLA VENTILATOR COMPANY
9668-D Heinrich Hertz Drive
San Diego, California 92154
619/946-1224 • Fax 619/946-1227
Romlair.com