



Model RBDS
Counter Balanced Intake Damper

Features:

- Wide Operating Range -Velocities Up to 3000 FPM.
- Blade Design for Weather Protection and Leadage.
- Pre-punched mounting hole in flange Frame Units.
- Mechanically locked blade seals.

Standard Construction:

- 20 Gauge Galvanized Steel Frame.
- .020 Aluminum Blades.
- Extruded vinyl blade seals locked Into Blades.
- Stainless Steel Axles.
- Stainless Steel Pins, Galvanized Steel Tie Bar.
- Mill Finish

ROMLA VENTILATOR CO.
9668 Heinrich Hertz Drive • Unit D
San Diego, CA 92154
Ph: (619) 946-1224 Fax: (619) 946-1227

Available Options:

- MP -Electric actuators
- CP -Chain pulls
- DS -Damper sleeve
- FF -Front flange frame
- RF -Rear flange frame

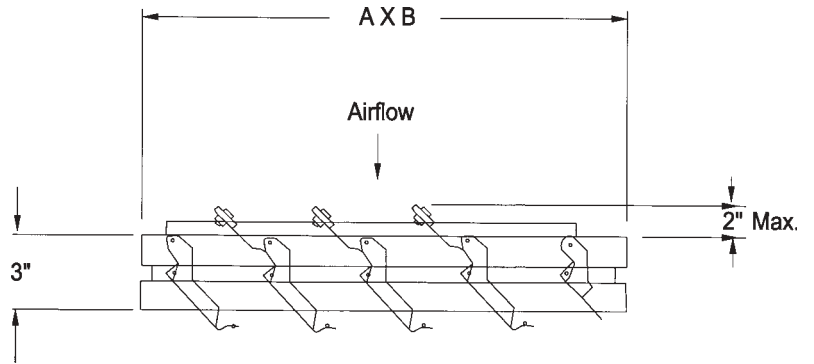

AIR FLOW DOWN
(Counter Balanced)
Channel Frame-Standard (Shown)

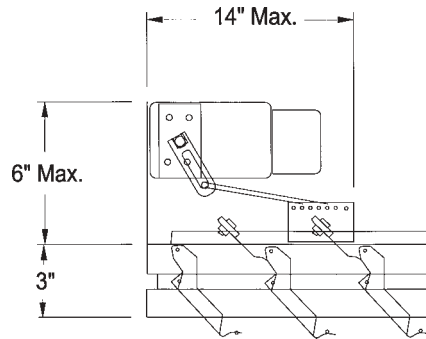

MA220/MA230
Optional Electric Actuator

* Note: Units furnished 1/4" smaller than given opening dimensions.

QTY	MODEL	OPENING DIM.		TYPE FRAME	ACTUATORS		VOLT.	OPTIONS
		A*	B*		INSTALLED	LOOSE		

<p>PROJECT: LOCATION: SUBMITTED BY: DATE:</p>	<p>CONTRACTOR: ENGINEER: APPROVED BY: DATE:</p>
---	---