

# MODEL HFS

(Aluminum Propeller)

*Romlair Model HFS Hooded Filtered Supply Fans provide fresh or make up air that is cleansed of dust and other entrapped particle matter. Model HFS helps the building owner and occupants to meet health and air pollution requirements.*

## Hooded Belt Driven Filtered Supply Fans

### CONSTRUCTION FEATURES

- **Two Propeller Options** – Cast aluminum airfoil propeller or six bladed high performance steel propeller.
- **Heavy Duty, Long-Life Construction** – Built to industrial standards. The heavy gauge galvanized hood utilizes an interlocking rib at the seams that provides superior strength. All welded fan base.
- **Variable Pitch Drives To 7-1/2 HP** – Adjustable for final system RPM. Belts sized for 165% of driven HP.
- **Hinged Hood** – Provides easy access to fan motor, belts, pulleys, and propeller.
- **Heavy Duty Ball Bearing Motor** – Provides years of trouble free operation.
- **Self-Aligning Pillow Block Bearings** – Selected for a minimum (L50) life in excess of 200,000 hours at maximum cataloged operating speeds.
- **Angle Drive Frame** – Bolted base assembly provides firm base and accurately aligns power assembly.
- **Deep Spun Venturi** – For high efficiency.
- **2" Aluminum Mesh Washable Filters** – Easily removable for clearing or replacement with hood open or closed.
- **UL Listing** – UL705 listing is available on TEFC models up to 10 Hp.
- **Polyurethane coating** – The exterior housing is coated with a polyurethane coating providing a long lasting protective finish.



***Romla also offers this fan in an exhaust filtered application, and a reversible flow application. Consult factory for details.***

# MODEL HFS CONSTRUCTION FEATURES

## BUILT TO INDUSTRIAL STANDARDS

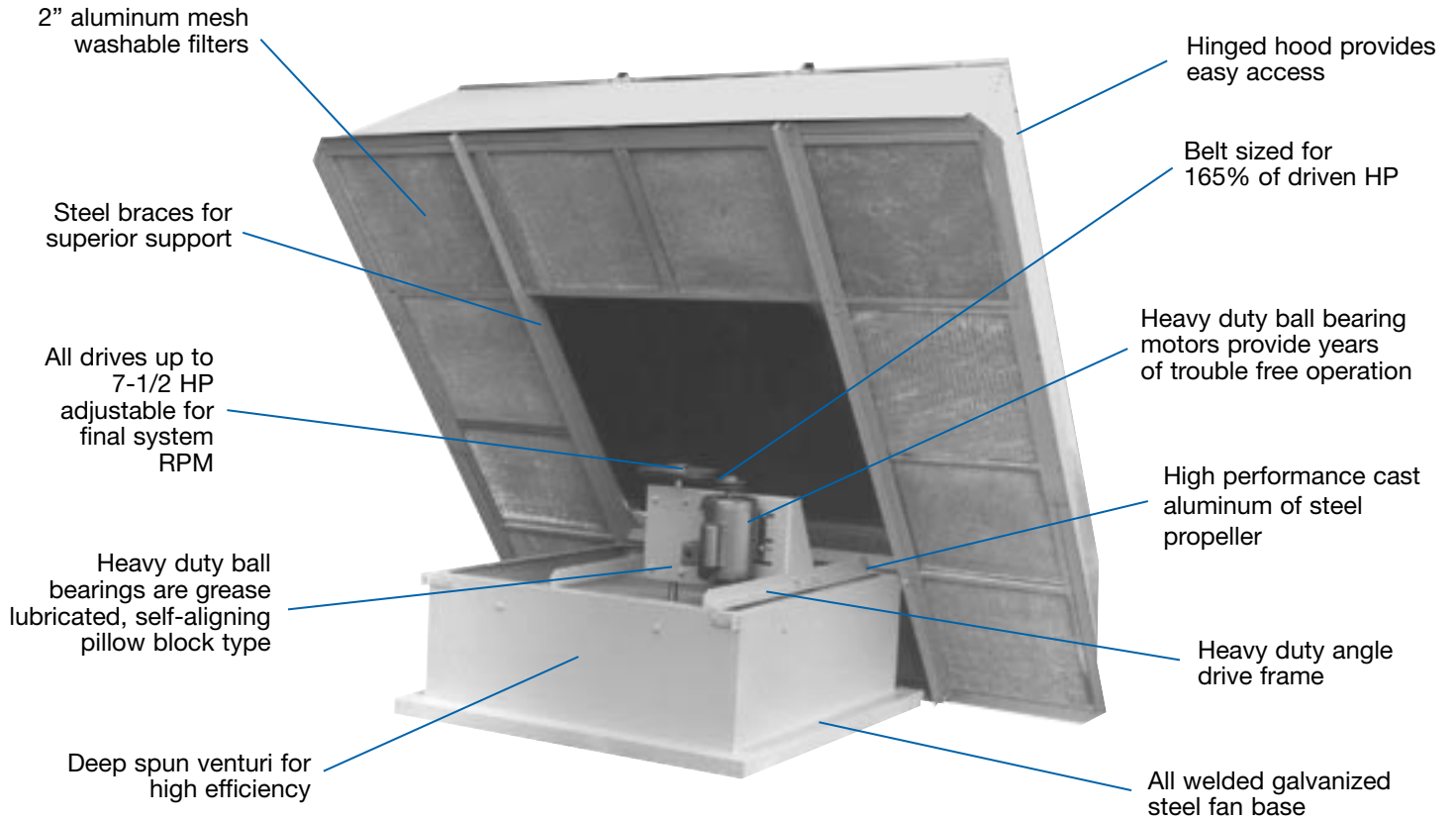

# MODEL HFS-S (STEEL PROPELLER) PERFORMANCE DATA

MODEL	HP	RPM	TIP SPEED	MAX BHP	*SONES	STATIC PRESSURE (ins. w.g.) / CAPACITY (cfm)						
						0	.10	.125	.25	.375	.50	.625
HFS-242S	1/3	751	4719	.36	17.5	5325	4793	4611	3196			
HFS-243S	1/2	862	5416	.54	22.1	6112	5671	5537	4484			
HFS-244S	3/4	994	6246	.84	27.1	7048	6690	6576	5853	4786	3703	
HFS-245S	1	1090	6849	1.10	29.3	7729	7413	7318	6790	5873		
HFS-303S	1/2	611	4799	.57	17.9	8398	7534	7255	4697			
HFS-304S	3/4	698	5482	.86	21.6	9594	8898	8659	6877	4384		
HFS-305S	1	758	5953	1.09	23.8	10419	9820	9600	8155	6006		
HFS-306S	1-1/2	867	6809	1.64	28.7	11917	11446	11277	10316	8713	6720	4721
HFS-363S	1/2	470	4430	.57	17.2	10651	8934	8290	4872			
HFS-364S	3/4	532	5014	.83	20.3	12056	10622	10169	7294			
HFS-365S	1	585	5514	1.11	23.0	13258	12025	11613	9129	6352		
HFS-366S	1-1/2	670	6315	1.66	27.3	15184	14217	13862	11892	9584	7109	
HFS-367S	2	735	6927	2.21	31.2	16657	15845	15540	13900	11801	9692	7408
HFS-368S	3	841	7926	3.31	38.9	19059	18350	18172	16791	15205	13370	11526
HFS-425S	1	424	4662	1.11	19.3	16523	14762	14226	10254			
HFS-426S	1-1/2	482	5300	1.65	21.7	18783	17333	16861	13716	10022		
HFS-427S	2	583	5861	2.21	24.4	22719	21622	21297	19347	16370	13464	10091
HFS-428S	3	615	6762	3.34	30.7	23966	22926	22640	20826	18223	15446	12409
HFS-486S	1-1/2	400	5027	1.87	23.8	21794	18938	18042	13352	8167		
HFS-487S	2	442	5554	2.21	26.8	24082	21620	20836	16768	12213	7405	
HFS-488S	3	505	6346	3.45	32.6	27515	25360	24821	21333	17606	13601	9393
HFS-548S	3	415	5867	3.31	25.2	32514	29786	28992	23507	18084		
HFS-549S	5	495	6998	5.53	32.8	38782	36652	35987	32100	27271	22624	
HFS-5410S	7-1/2	569	8044	8.26	48.3	45580	42861	42297	39403	35507	31193	26982
HFS-608S	3	346	5435	3.30	25.1	37747	33649	32441	25277	18532		
HFS-609S	5	410	6440	5.52	35.9	44729	41520	40501	34722	28880	23293	
HFS-6010S	7-1/2	471	7398	8.26	43.3	51384	48769	47945	43509	37846	32978	28281
HFS-6011S	10	518	8137	11.05	53.0	56511	54134	53514	49541	44859	39979	35577

# MODEL HFS-A (CAST ALUMINUM AIRFOIL PROPELLER) PERFORMANCE DATA

MODEL	HP	RPM	TIP SPEED	MAX BHP	*SONES	STATIC PRESSURE (ins. w.g.) / CAPACITY (cfm)						
						0	.10	.125	.25	.375	.50	.625
HFS-242A	1/3	910	5718	.38	14.5	4952	4308	4124	3036			
HFS-243A	1/2	1044	6560	.57	16.8	5682	5140	4983	4108	3115		
HFS-244A	3/4	1189	7471	.85	19.3	6471	6017	5880	5157	4327	3453	
HFS-245A	1	1307	8212	1.12	22.6	7113	6713	6594	5968	5249	4461	3662
HFS-303A	1/2	773	6071	.54	14.4	7486	6670	6431	5015	3570		
HFS-304A	3/4	889	8609	.83	17.9	8609	7938	7732	6599	5357	4061	
HFS-305A	1	971	7626	1.09	20.4	9403	8808	8629	7675	6465	5404	4150
HFS-363A	1/2	664	6258	.58	16.9	9837	8611	8248	5822			
HFS-364A	3/4	757	7135	.85	19	11215	10190	9880	7978	5582		
HFS-365A	1	834	7860	1.15	21.5	12356	11459	11187	9688	7652	5293	
HFS-366A	1-1/2	930	8765	1.59	24.6	13778	13015	12771	11498	9837	7990	5846
HFS-367A	2	1020	9613	2.10	27.7	15111	14454	14232	13098	11837	10130	8395
HFS-368A	3	1166	10989	3.13	32.9	17274	16719	16567	15597	14579	13441	11894
HFS-425A	1	680	7477	1.15	19.6	14686	13171	12731	10333			
HFS-426A	1-1/2	759	8346	1.61	23	16392	15081	14695	12678	10465		
HFS-427A	2	836	9192	2.15	26.6	18055	16902	16561	14780	12754	10893	
HFS-428A	3	961	10567	3.27	32.5	20754	19810	19514	17987	16409	14592	12958
HFS-429A	5	1140	12535	5.45	42.5	24620	23850	23657	22408	21094	19788	18331
HFS-486A	1-1/2	664	8344	1.62	24	20339	18621	18098	15230	11739		
HFS-487A	2	734	9224	2.18	26.1	22483	20993	20532	18098	15095	11914	
HFS-488A	3	845	10619	3.33	33.2	25883	24690	24289	22235	20022	17311	14549
HFS-489A	5	993	12478	5.40	40.4	30416	29438	29193	27487	25706	23855	21575
HFS-548A	3	605	8553	3.19	25.4	29908	28144	27611	24720	21304	17729	
HFS-549A	5	716	10122	5.29	31.9	35395	34030	33580	31255	28748	25861	22750
HFS-5410A	7-1/2	815	11522	7.81	39.5	40289	39104	38808	36828	34711	32469	29952
HFS-608A	3	532	8357	3.18	26.2	34440	32054	31338	27403	22713		
HFS-609A	5	631	9912	5.32	33.5	40849	38957	38380	35278	31847	27795	23914
HFS-6010A	7-1/2	719	11294	7.84	40.4	46546	44981	44488	41873	39010	35966	32331
HFS-6011A	10	793	12456	10.56	47.6	51337	44918	49563	47269	44760	42087	39292

**NOTE:** Romla Co. certifies that the fans shown have been tested and rated in accordance with AMCA Bulletin 211 and are guaranteed by the manufacturer to deliver rated performance.

\*Sones shown apply to the highest cataloged CFM at each fan RPM.

**MAX. BHP:** The brake horsepower capability of a fan motor is dependent on the degree of cooling the motor receives from the moving air stream over the motor. The motor loading beyond the motor name plate rating on Romla-built fans does not overheat the motor and is within NEMA recommended limits.

# MODEL HFS DIMENSIONAL DATA

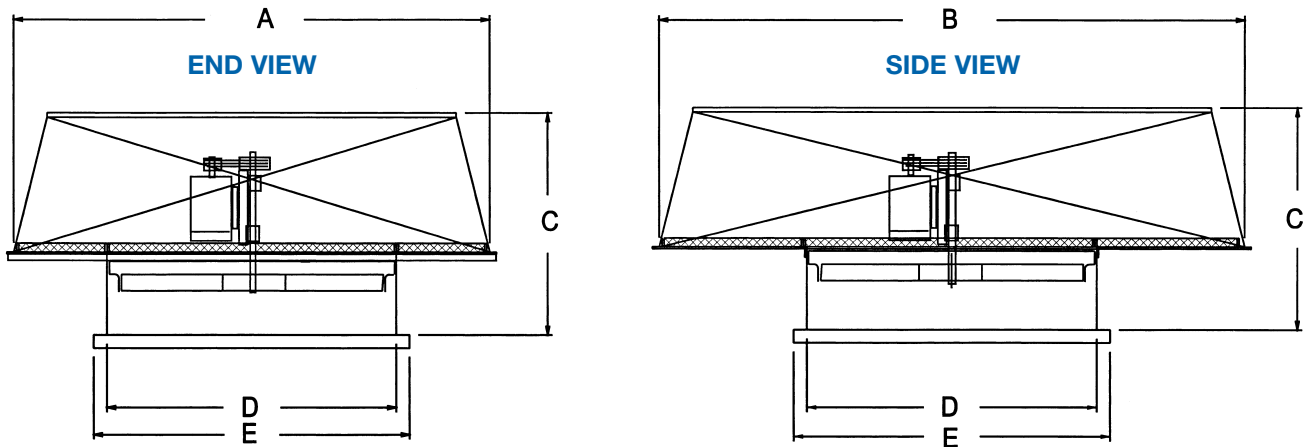

FAN SIZE	DIMENSIONS (inches)					BASE GAUGE	HOOD GAUGE	DAMPER SIZE (ins. sq.)	ROOF OPENING (ins. sq.)	APPROX. WEIGHT (lbs.)
	A	B	C	D	E					
24	71	71	32	30.25	36	16	20	24	26.5	295
30	81	81	34	36.25	42	16	20	30	32.5	370
36	91	91	37	42.25	48	16	20	36	38.5	615
42	99	99	38	48.25	54	16	20	42	44.5	725
48	99	120	43	54.25	60	14	20	48	50.5	850
54	99	144	47	60.25	66	14	18	54	56.5	975
60	116	144	50	66.25	72	14	18	60	62.5	1200

## MODEL HFS ACCESSORIES

- **DAMPERS** – Model RBD counterbalance backdraft dampers. Motorized operation is available.
- **HEAVY-DUTY BACKDRAFT DAMPERS** – Model RVC motorized heavy duty center pivot control dampers can be used on supply applications. Designed for higher velocity application and are available in standard leakage and low leakage applications. All low leakage dampers include vinyl blade and jamb seals.
- **ROOF CURBS** – Type CF and SF prefabricated roof curbs are available to ensure compatibility between the fan, curb, and roof opening.
- **U.L. 705** – All belt driven fans up to 10 HP with TEFC standard efficiency and premium efficiency single speed motors are available with the UL-705 listing for electrical.
- **SAFETY GUARDS** – Safety guards installed at the fan inlet are recommended to protect the fan and nearby personnel in nonducted applications. Where a safety guard is not ordered with the fan, it should be provided by the installer.
- **SPECIAL COATINGS** – Special liquid coatings are available, including special color to match enamels, epoxies, and urethanes. Urethane powder coating are also available. Consult factory for information regarding which coating to use.
- **DISCONNECT SWITCHES** – The following switches are available. They are factory mounted non-wired. Optionally, wiring from the motor to the disconnect box can be provided. NEMA 1 - Indoor general purpose, NEMA 3R - Exterior mount, rain-tight, NEMA 4 - Water-tight and dust-tight.
- **EXTENDED LUBRICATION LINES** – All the pillow block bearings to be lubricated without hinging the hood.
- **HOOD INSULATION** – 1/2" or 1-1/2" thickness insulation is available to minimize condensation and reduce sound levels.
- **HIGH WIND TIE DOWN POINTS** – In high wind locations, cable tie downs (by others) are recommended to secure fans to the roof. Four tie down points for cable attachment can be provided.

## SPECIFICATIONS

Roof mounted filtered supply hooded power roof ventilators shall be belt driven axial type. Fan shall be belt driven and incorporate a cast aluminum airfoil propeller or 6 bladed high performance steel propeller. Propellers shall be statically and dynamically balanced. The fan housing shall be heavy gauge galvanized steel with vertical welded seams. The fan hoods shall be constructed of heavy gauge galvanized steel with interlocking ribs at the seams to provide superior strength. Hoods shall be hinged to provide easy access to fan components such as motors, belts, pulleys, and propellers. 2" washable aluminum filters shall be installed in the hood, easily removable both with the hood open and the hood closed. Self-aligning pillow block bearings shall be selected for a minimum (L50) life in excess of 200,000 hours at maximum cataloged operating speeds. Fan drives shall be designed for 165% of driven HP. Motor drives to 7-1/2 HP shall be variable pitch. Belts shall be oil resistant non-static type. Fans shall be Model HFS as manufactured by Romla Ventilator Company of San Diego, California.

## WARRANTIES

The Romla Ventilator Company warrants this equipment to be free from defects in material and workmanship under normal use and service for a period of one year from date of delivery. During the warranty period if any parts prove to be defective, they will be repaired or replaced free of charge at factory option: If upon receipt of written authorization they are delivered prepaid to the factory. This guarantee does not cover any damage caused by neglect of lubrication, accident or overload, improper installation, nor does it cover the cost of repairs made or attempted outside the factory, without authorization from Romla Co. Electric motors are guaranteed only to the extent of the motor manufacturer's warranty.

Romla Ventilator Company is not responsible for the cost of removal of the defective product or part, or the installation of the repaired or replaced products or part. Correction of any verified defects by repair or replacement shall constitute fulfillment of this warranty.



**WARNING! DO NOT USE IN HAZARDOUS ENVIRONMENTS** where fans electrical system could provide ignition to combustible or flammable materials, unless unit is specifically built for hazardous environments. Guards must be installed when fan is within reach of personnel or within seven (7) feet of working level or when deemed advisable for safety.



**ROMLA VENTILATOR COMPANY**  
 9668 Heinrich Hertz Drive, Unit D  
 San Diego, California 92154  
 619/946-1224 • Fax 619/946-1227 • [www.romlair.com](http://www.romlair.com)

## DISTRIBUTED BY

